

SG series linear guide dimension table

○ SGH-B/SGH-BL/SGS-B

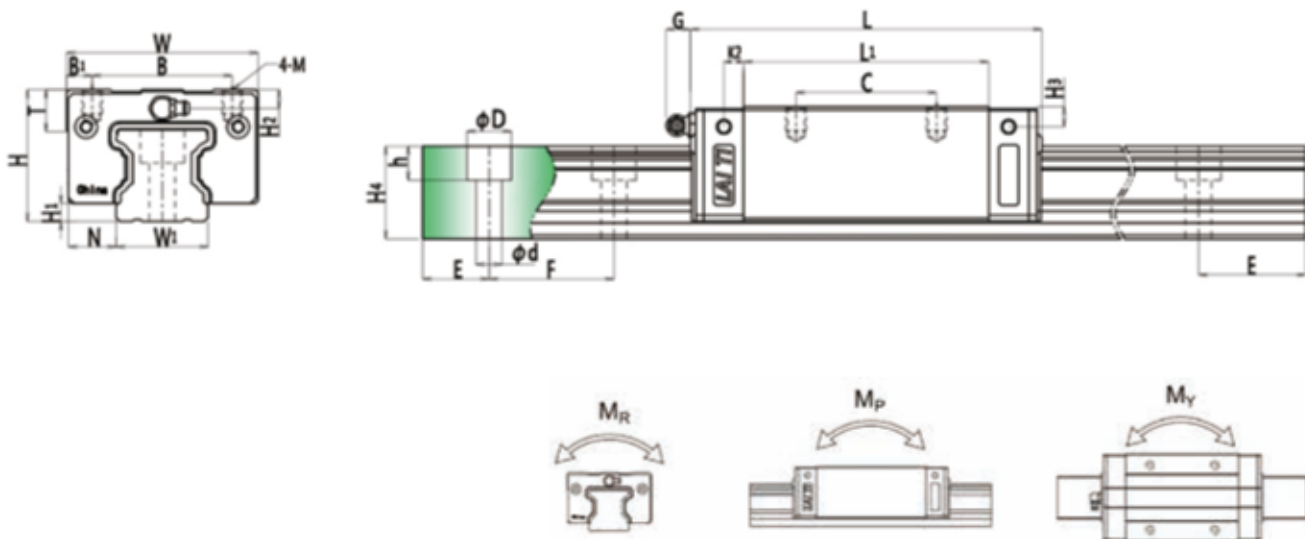

Linear Guide parameter

Note: 1kgf=9.81N

Model	Assembly dimension (mm)			Block dimension (mm)								Rail dimension (mm)								Basic dynamic load capacity $C_{dyn}(kN)$	Basic static load capacity $C_0(kN)$	Static permissible moment		
	H	H ₁	N	W	B	C	L ₁	L	MxL	H ₂	H ₃	W ₁	H ₄	D	h	d	F	E	M _R KN-m			M _p KN-m	M _y KN-m	
SGH15B	28	3	9.5	34	26	26	39.2	58.2	M4X5	8	7.6	15	14.9	7.5	5.3	4.5	60	20	14.21	18.53	0.19	0.14	0.14	
SGS15B	24	3	9.5	34	26	26	39.2	58.2	M4X5	4	3.6	15	14.9	7.5	5.3	4.5	60	20	13.56	17.65	0.19	0.14	0.14	
SGH20B	30	3.7	12	44	32	36	52.5	80	M5X6	5	5.8	20	20	9.5	8.5	6	60	20	24.23	31.28	0.37	0.28	0.28	
SGH20BL						50	65.2	93																27.66
SGS20B	28	3.7	11	42	32	32	52.5	80	M5X6	4	3.8	20	20	9.5	8.5	6	60	20	24.23	31.28	0.37	0.28	0.28	
SGH25B	40	4.5	12.5	48	35	35	61	85	M6X8	11.6	12	23	23	11	9	7	60	20	35.24	44.31	0.60	0.49	0.49	
SGH25BL						50	80.3	104.7																42.58
SGS25B	33	4.5	12.5	48	35	35	61	85	M6X8	4.6	5	23	23	11	9	7	60	20	19.38	23.04	0.60	0.49	0.49	
SGH30B	45	7	16	60	40	40	69	97	M8X10	9	10	28	28.4	14	12	9	80	20	46.53	56.24	0.95	0.7	0.7	
SGH30BL						60	92.3	120.3																58.89
SGS30B	42	7	16	60	40	40	69	97	M8X10	6	7	28	28.4	14	12	9	80	20	27.92	33.74	0.95	0.7	0.7	
SGH35B	55	7.6	18	70	50	50	79	109	M8X12	14.4	14.4	34	31.9	14	12	9	80	20	61.22	80.30	1.73	1.09	1.09	
SGH35BL						72	105	135																78.16
SGS35B	48	7.6	18	70	50	50	79	109	M8X12	7.4	7.4	34	31.9	14	12	9	80	20	39.79	52.20	1.73	1.09	1.09	
SGH45B	70	9.7	20.5	86	60	60	97.8	138	M10X17	18	18	45	39.85	20	17	14	105	22.5	98.43	112.66	3.56	2.35	2.35	
SGH45BL						80	132.3	173																125.58

1-1-6 Stainless steel cover strip introduction and related accessories

1. Development specification model

Series	Specification
SG	20, 25, 30, 35, 45

2. Stainless steel cover strip advantages

- Stainless steel sus304
- Fast mounting
- Avoid damage to the oil scraper seal by bolt holes
- Prevent external dust from entering the block from the bolt hole

3. Dust-proof steel belt related accessories

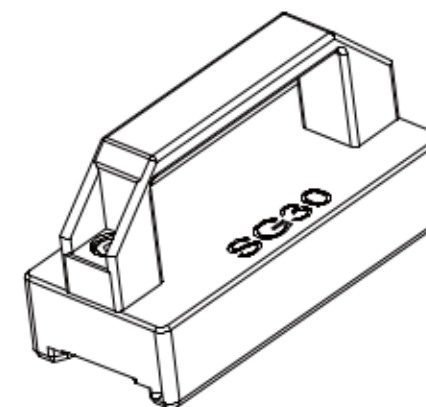

Steel belt installation tool



Steel strip removal tool

The SG dust-proof steel strip is mounted on the rails (the rail length is below four meters and is not connected)

1. Stainless steel strip mounting

A steel strip with a rail length of less than four meters will be snapped on to the rail directly.

